

### Product description:

TPU 95A is a thermoplastic polyurethane filament with a Shore hardness of 95A, providing a combination of elasticity, abrasion resistance, and durability. It is designed for parts that require flexibility, impact resistance, and high wear resistance. TPU 95A is compatible with most FDM/FFF 3D printers and is ideal for printing elastic, yet strong, parts.

### Storage:

Store in dry area, in a closed container away from moisture.

### PRODUCT PARAMETERS

Parameter	Value
Filament diameter [mm]	1.75
Diameter tolerance [mm]	+/- 0,03
Oval tolerance [mm]	+/- 0,03

Spool dimensions [mm] ( $\phi$ / height / hole $\phi$ )	200/57/52
Spool weight [g]	325
Spool material	Transparent PC
Weight with packaging [g]	1 550
Net weight [g]	1 000
Box dimensions [mm]	203/207/70

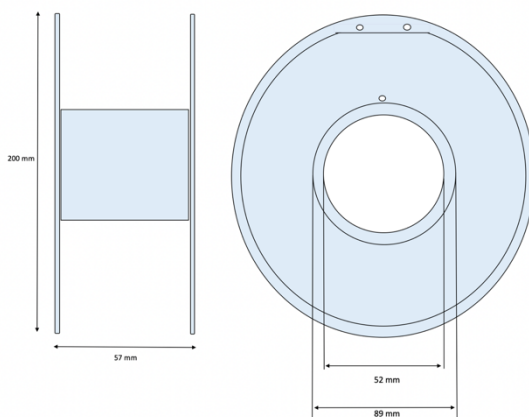

### RECOMMENDED PRINTING PARAMETERS

Parameter	Value
Print temperature [°C]	210-240
Bed temperature [°C]	30-60
Cooling [%]	Low or moderate (20-50%)
Closed chamber	Not required
Chamber temperature [°C]	30-40
Printing Speed [mm/s]	20-60
Retraction Settings	Minimize or disable retraction

### PHYSICAL PARAMETERS OF THE MATERIAL

Parameter	Value	Unit	Test method
Density	1,25	g/cc	ISO 1183
Melt flow rate	6-8	g/10min	ISO 1133 220°C/10Kg
Vicat softening temp.	80-90	°C	ISO 306 VST/A/50 (50°C/h,10N)
Tensile modulus	12-15	MPa	ISO 527 1mm/min
Tensile strength	30	MPa	ISO 527 @Yield 50mm/min (2inch/min)
Elongation at break	500	%	ISO 527 @Break 50 mm/min (2inch/min)
Impact strength	High	KJ/m2	ISO 179 Charpy Notched @23°C (73°F)

The values above have been measured using standard test specimens made of non-colored material at room temperature. The figures should be considered as indicative values only. Actual properties of TPU 95A parts can be affected by the printing parameters, design of the model, ambient conditions, application of the printout etc. It is essential that users test our products to determine whether they are suitable for their intended use.